

Badass Auger™

Assembly and Use Instructions

Auger Assembly Detail

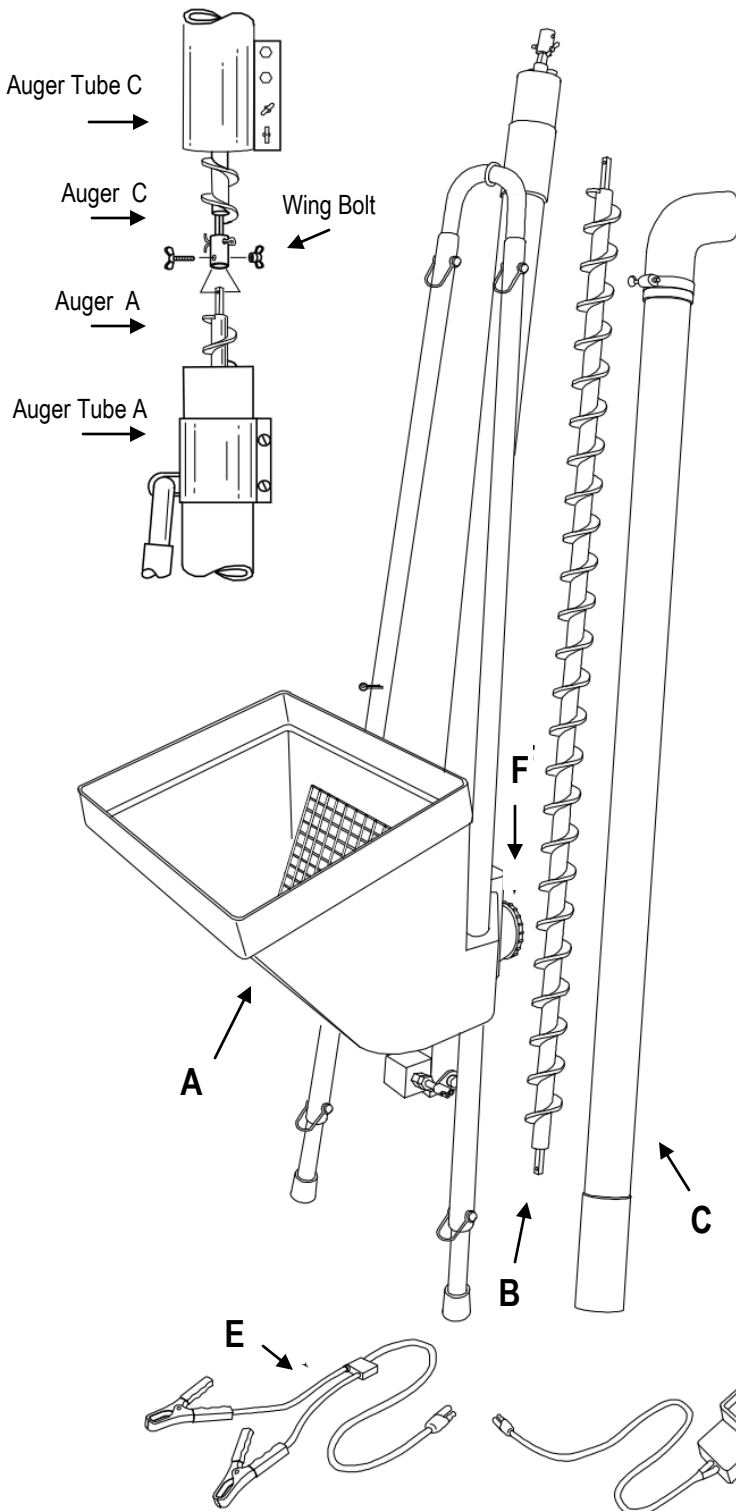

ASSEMBLY

1. Make sure all parts pictured are present.
2. Open black bag and remove package with wing bolts.
3. Lay part "A" flat on the ground.
4. Attach auger "B" to auger "A" with wing bolt . Tighten securely.
5. Slip tube "C" over auger "B" and tube "A" . Tighten wing bolts.
6. Plug controller "D" to motor on part "A".
7. Plug opposite end wire of controller "D" to battery pigtail plug "E".
8. "IMPORTANT" Connect negative (Black) alligator clamp to any metal part on engine compartment.
9. Connect Red alligator clamp to the Positive battery post.

USE INSTRUCTIONS– READ CAREFULLY

Read and obey all warning labels on the Badass Auger.

IMPORTANT: Make sure feeder being filled is level and legs are securely anchored to the ground.

NEVER extend Badass Auger legs beyond 24 inches.

NEVER place more than 50 lbs of weight on hopper.

NEVER turn your back on feeder being filled.

1. If possible, load the Badass Auger from tailgate-level of your vehicle. **SAVE YOUR BACK**
2. Place 50 lb bag of feed into the hopper. Using a knife, cut the bottom of the bag open, letting contents spill into the hopper OR, pour the contents of a bag directly into the hopper.
3. Holding the controller, press the FWD button to fill the feeder. When the hopper is empty, repeat steps 2 & 3.
4. When feeder is full and if hopper still has feed in it, place an empty bag under hopper and unscrew drain cap "F" to empty contents of hopper into bag.
5. **ONLY AFTER HOPPER IS EMPTY** press REV button on the controller to empty feed from auger tube. **DO NOT PUT FINGERS INTO DRAIN HOLE.** Replace drain cap.
6. Disassemble auger tube when transporting to avoid damage.
7. When filling multiple feeders, disconnect plug "D" from plug "E". Leave plug "E" connected to battery, hanging out of vehicle hood, being careful wire is not damaged. Travel to next feeder and repeat step 1-6.